

# ZOOMLION

## ARTICULATING BOOM LIFTS

### ZA32J

Comply with CE/ANSI/CSA Standard

#### FEATURES

##### Standard Features

Horn
All motion alarm
Proportional control
Self-closing entry gate
Flashing beacon
Auto-leveling system
Emergency stop button
Over tilt protection system
Emergency descent system
On-board diagnostic system
Oscillating axle
4.3' LED display
Load sensing system
Swing-out engine tray

##### Accessories & Options

- ▶ Platform work lights
- ▶ Secondary guarding system
- ▶ Anti-collision device
- ▶ AC power to platform

#### HIGHLIGHTS

- ▶ Provide heavy lifting of 250kg/550lb load for 28% higher efficiency
- ▶ Build-in multiple pressure control leveling system to enhance stability
- ▶ Precise load sensing system to improve overload safety operations
- ▶ Deadweight Lowering System for smooth operation and energy efficiency
- ▶ Outstanding below ground reach of 3.6m (11ft 10in)

## ACCESS WITH ZOOMLION GREEN

Phone: 0086(731)-88353680 0086(731)-88250971  
E-mail: awm@zoomlion.com

Add: ZOOMLION Wangcheng Industrial Park, Tengfei Road 997, Changsha, Hunan, China  
Web: www.en.zoomlion.com

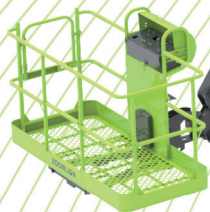

# ARTICULATING BOOM LIFTS

## ZA32J

Comply with CE/ANSI/CSA Standard

Model	ZA32J	
	Imperial	Metric
<b>Size</b>		
Work Height	111ft 1in	33.85m
Platform Height	104ft 6in	31.85m
Horizontal Outreach	69ft 5in	21.17m
Up and Over Height	47ft 8in	14.52m
A - Stowed Length	41ft 4in	12.6m
B - Stowed Width	8ft 2in	2.49m
C - Stowed Height	10ft 2in	3.1m
D - Platform Length	8ft	2.44m
E - Platform Width	2ft 12in	0.91m
Jib Length	8ft	2.44m
F - Wheelbase	12ft 6in	3.81m
G - Ground Clearance	1ft 5in	0.42m
<b>Performance</b>		
Platform Capacity	550 lb	250kg
Drive Speed	3.23 mph	5.2km/h
Gradeability	45% (24°)	45% (24°)
Axles Oscillation	8in	0.2m
Turning Radius (Inside)	25ft 3in/10ft 10in	7.7/3.3m
Turning Radius (Outside)	35ft 5in/26ft 11in	10.8/8.2m
Swing	360° continuous	
Platform Rotation	±90°	
H-Tail Swing	0	
Max. Wind Speed	28mph	12.5m/s
<b>Power</b>		
Diesel Engine	Cummins QSF2.8	
Engine Power	75hp/2400rpm	54kW/2400rpm
Fuel Tank Capacity	52.8 (us gal)	200L
Auxiliary Power	12V	
Control Voltage	12V	
Hydraulic System Capacity	79.3 (us gal)	300L
Hydraulic Tank Capacity	52.8 (us gal)	200L
Drive	445/50D710 Foam-filled Tires	
<b>Tire</b>		
Type	315/55 D20 Foam-filled Tires	
<b>Weight</b>		
Gross	43431 lb	19700kg

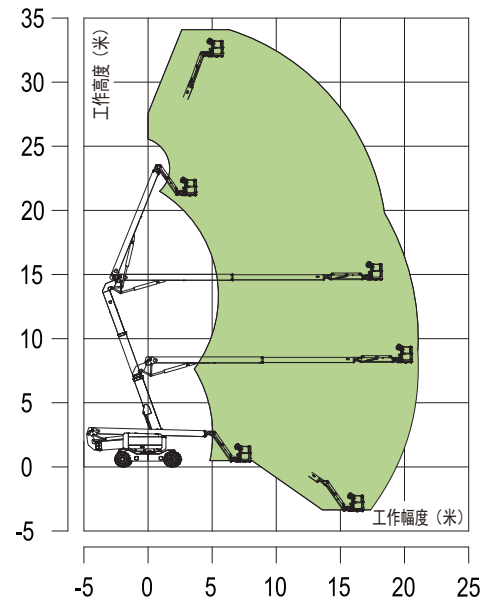
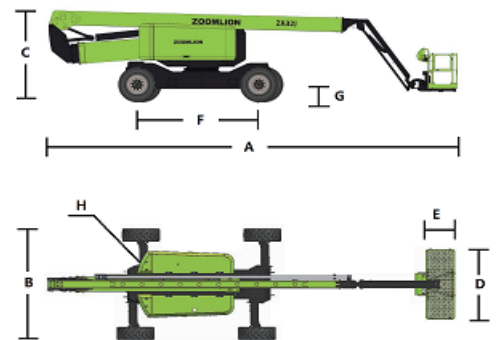

Range of Motion ZA32J